



**ThermoFlo Heater Assembly  
(for PACE ThermoFlo Handpieces)  
PACE PART NUMBER 6010-0091-P1 (115 Volt Systems)  
PACE PART NUMBER 6010-0092-P1 (230 Volt Systems)  
Installation Instructions  
MANUAL NUMBER 5050-0429 REV. B**

**CAUTION**

**POTENTIAL SHOCK HAZARD** - Disassembly of handpiece exposes line voltage parts. Replacement of heater assembly must be performed by qualified service personnel only. Contact the PACE Service Department for assistance at 301-490-9860.

Insure that the ThermoFlo heater (on handpiece) is at room temperature & perform the following procedure using the illustrations as a guide.

**NOTE**

Insure that you have the correct replacement heater assembly. Part number 6010-0091-P1 is for use with 115 VAC systems only, part number 6010-0092-P1 is for use with 230 VAC systems.

1. Remove and set aside any installed nozzle.
2. Turn the power switch (on ThermoFlo power source front panel) Off ("0" position) and disconnect the power supply cable from the AC supply.
3. Remove the handpiece from the work platform if it is mounted on this optional accessory.
4. Remove the plastic Heat Shield (or metal swivel ring if used on work platform) from the handpiece.
5. Position the Vacuum Pick Assembly to extend as far into the handpiece as possible using the Vacuum Pick Adjust Control.

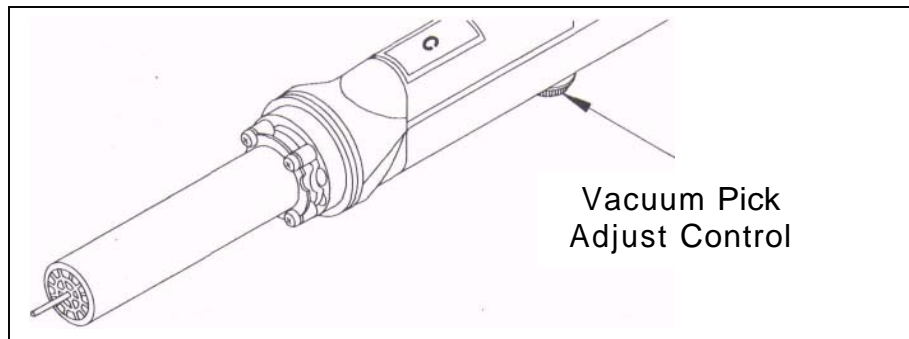
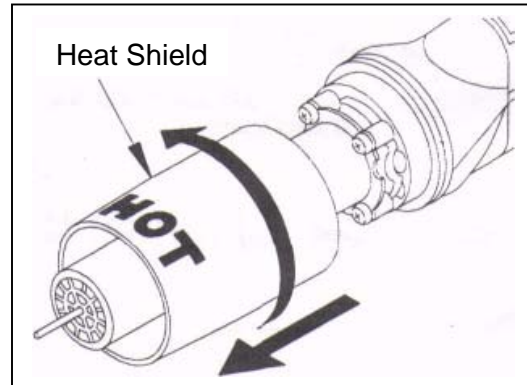

6. Position the handpiece as shown with the Cycle (marked "C") and Vacuum (marked "V") Switches facing up as shown.

7. Remove the four (4) Heater Mounting Screws that secure the Heater assembly to the handpiece. Gently pull the Heater Assembly away from the handpiece.
8. The five (5) Heater Pins will disconnect from the handpiece. Set the Heater Assembly aside (discard at end of procedure).

**NOTE**

Do not rock the Heater Assembly when pulling from handpiece. Damage to the ceramic portion of the assembly may result

9. There is a Gray foam gasket attached to the Heater Assembly. Insure that no part of this Gray gasket remains on the handpiece. A new gasket is mounted on the replacement Heater Assembly.
10. Install the replacement Heater Assembly in the following manner.
  - a) Place the new Heater Assembly over the end of the Vacuum Pick Tube.
  - b) Insert the end of the Vacuum Pick Tube into the center, ceramic portion of the Heater Assembly.

**CAUTION**

Damage to the Heater Assembly could occur if the Vacuum Pick Tube is inserted incorrectly.

- c) Gently move the Heater Assembly close to the handpiece and guiding the end of the Vacuum Pick Tube through the center of the wire grill at the end of the Heater Assembly.

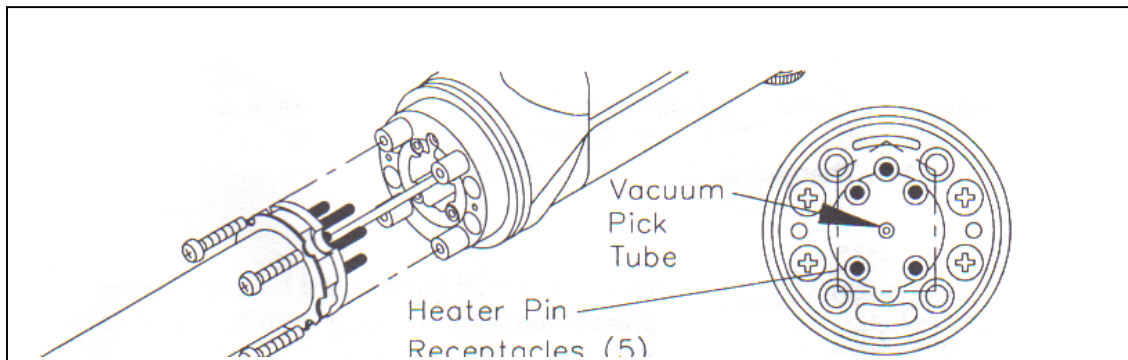

- d) There are five (5) Heater Pins at the rear of the Heater Assembly. Three (3) are next to each other on one section of the assembly. Two (2) pins are located next to each other in an opposing location. Position these pins so they line up with the five (5) matching Receptacles on the handpiece. Refer to illustration.
  - e) Gently push the Heater Assembly against the handpiece; forcing the Heater Pins into the matching Receptacles.
11. Install the 4 Heater Mounting Screws removed in step 7.
12. Install the Heat Shield (or Swivel Ring) removed in step 4.



**PACE Incorporated**  
9030 Junction Drive  
Annapolis Junction,  
MD 20701  
Tel: (301) 490-9860  
Fax: (301) 498-3252

**PACE Europe Limited**  
13 Tanners Drive  
Blakelands  
Milton Keynes  
Tel: (44) 1908-277666  
Fax: (44) 1908-277777